

# Lecture : 6

## Limits for Si MOSFETs (Continued)

# Other MOSFET LIMITS

- Performance limit (last time)
- Size limit
  - Estimate based on quantum principles (this lecture)
  - Estimate based on short channel effects
  - Estimate based on band-to-band tunneling.

# Limit Results From High $I_{OFF}$ (Not a Good Switch)

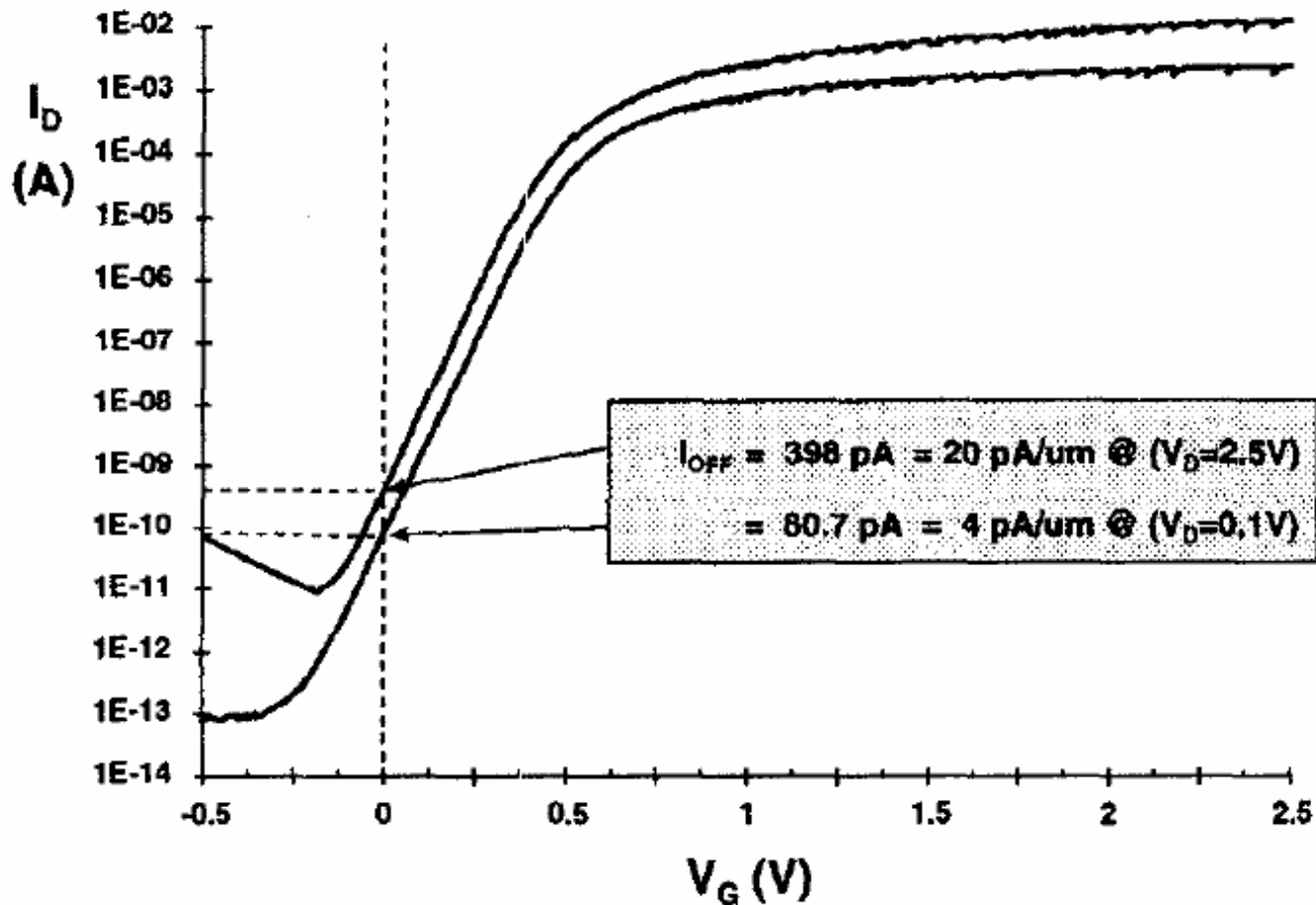

Intrinsic Leakage in Low Power Deep Submicron CMOS Ali Keshavarzi et. al.

# MOSFET Size Limit Today: A Quantum Mechanical Estimate

## Limits to Binary Logic Switch Scaling—A Gedanken Model

---

VICTOR V. ZHIRNOV, RALPH K. CAVIN, III, FELLOW, IEEE,  
JAMES A. HUTCHBY, SENIOR MEMBER, IEEE, AND GEORGE I. BOURIANOFF, MEMBER, IEEE

*Invited Paper*

# Again, Simple Model for MOSFET

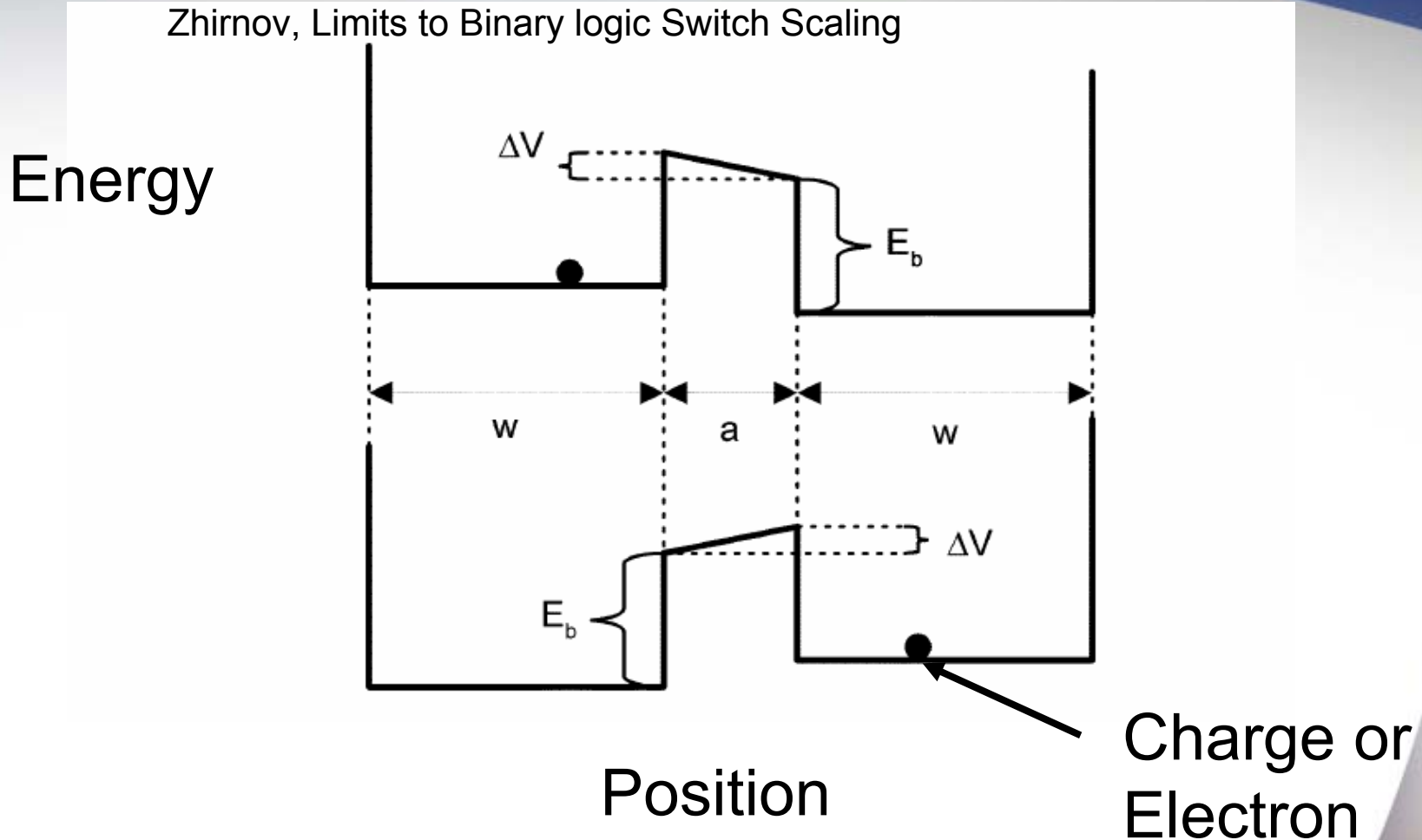

Many factors limit MOSFET size: tunneling, drain controlling barrier

# Introduction

- **Last Time: Matter Waves**
  - **Theory: de Broglie (1924) proposes matter waves**
    - assumes all “particles” (e.g. electrons) also have a wave associated with them with wavelength determined by its momentum,  $\lambda = h/p$ .
    - Bohr’s quantization follows because the electron in an atom is described by a “standing electron wave”.
  - **Experiment: Davisson-Germer (1927) studies electron scattering from crystals - see interference that corresponds exactly to the predicted de Broglie wavelength.**
  - **The Schrodinger equation: Master Equation of Quantum Mechanics: like Newton’s equation  $F=ma$  in classical mechanics.**
    - But what waving?
- **Today: Probability is intrinsic to Quantum Mechanics; Heisenberg Uncertainty Principle**

# Uncertainty Principle and Matter Waves

- The uncertainty principle can be understood from the idea of de Broglie that particles also have wave character
- What are properties of waves
  - Waves are patterns that vary in space and time
  - A wave is not in only one place at a give time - it is “spread out”

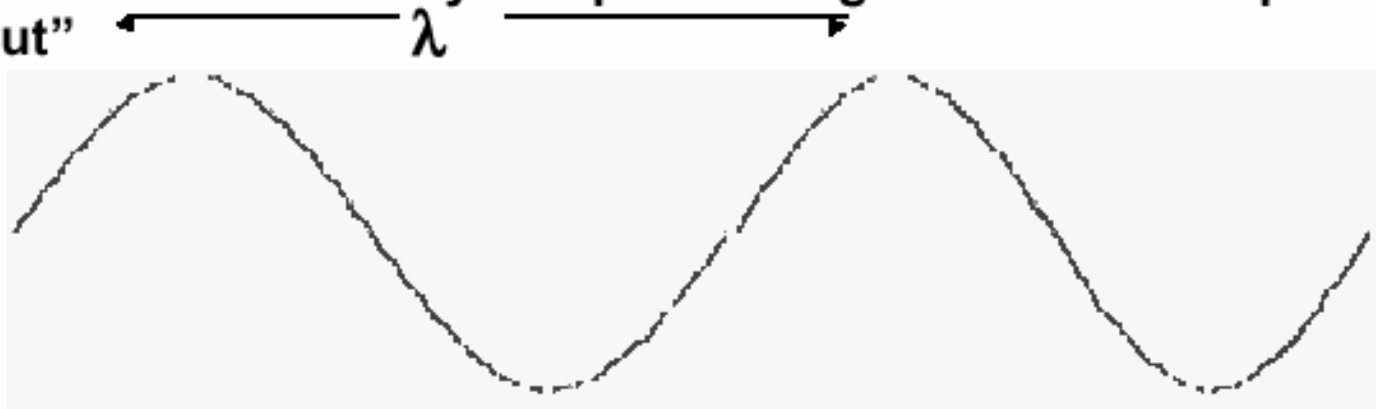

- Example of wave with well-defined wavelength  $\lambda$  and momentum  $p = h/\lambda$ , but is spread over all space, i.e., its position is not well-defined

## The Nature of the Wave function $\Psi$

- **Max Born proposed:  
 $\Psi$  is a probability amplitude wave!**
- **$\Psi^2$  tells us the probability of finding the particle at a given place at a given time.**
- **$\Psi$  is well-defined at every point in space and time**
- **But  $\Psi$  cannot be measured directly - Its square gives the probability of finding a particle at any point in space and time**

# Probability interpretation for $\Psi^2$

- The location of an electron is not determined by  $\Psi$ . The probability of finding it is high where  $\Psi^2$  is large, and small where  $\Psi^2$  is small.
- Example: A hydrogen atom is one electron around a nucleus. Positions where one might find the electron doing repeated experiments:

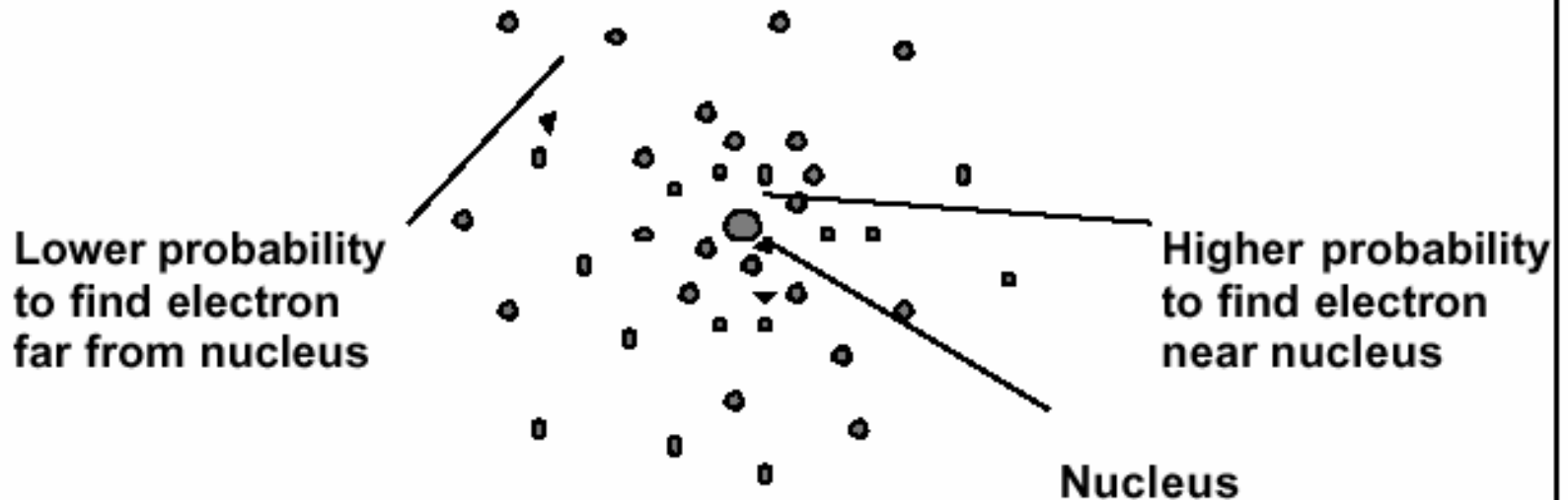

# How can one construct a Localized Wave?

- An extended periodic wave is a state of definite momentum

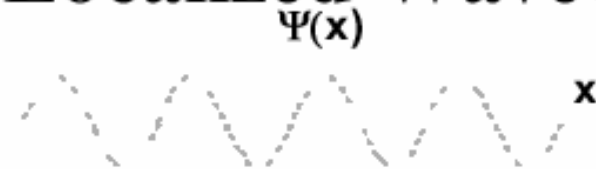

- Note: This wave is not localized!
- Problem: How to describe a localized wave?
- Solution: Add other waves to form a “wave packet”.

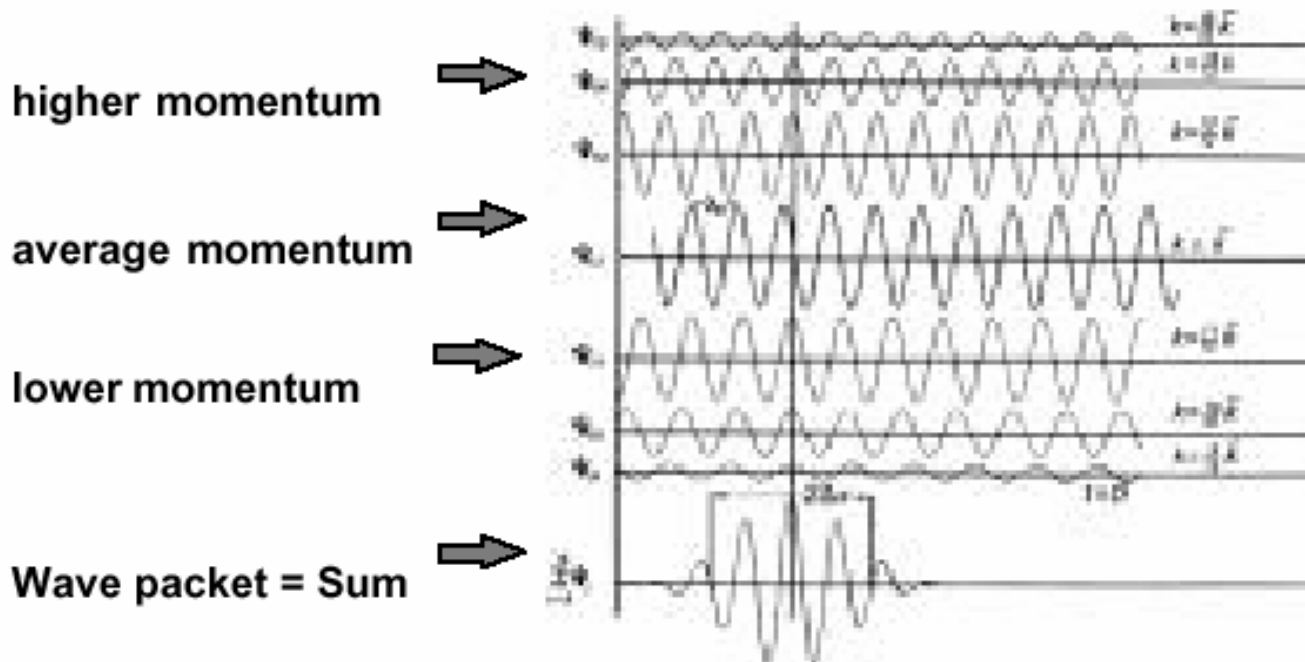

## The Nature of a Wave - continued

- Example of wave with well-defined position in space but its wavelength  $\lambda$  and momentum  $p = h/\lambda$  is not well-defined, i.e., the wave does not correspond to a definite momentum or wavelength.

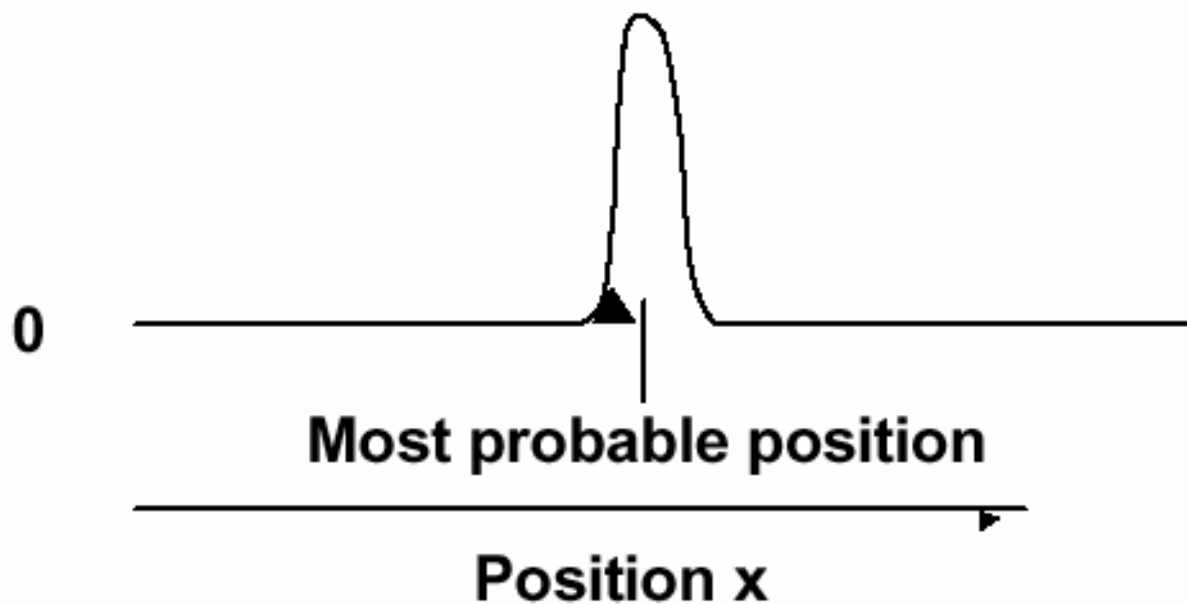

## Localized Wave Packet

- In order to have a wave localized in a region of space  $\Delta x$ , it must have a spread of momenta  $\Delta p$
- The smaller  $\Delta x$ , the larger the range  $\Delta p$  required
- Leads to the Heisenberg Uncertainty Principle:

$$\Delta p \Delta x \geq \sim h$$

- Can understand from de Broglie's Equation

$$\lambda = h / p$$

or

$$p \lambda = h$$

- The minimum range  $\Delta x$  is of order the wavelength  $\lambda$  which requires a range of momenta  $\Delta p$  at least as large as  $\Delta p \Delta x \geq \sim h$

# Last time: Simple Model for MOSFET

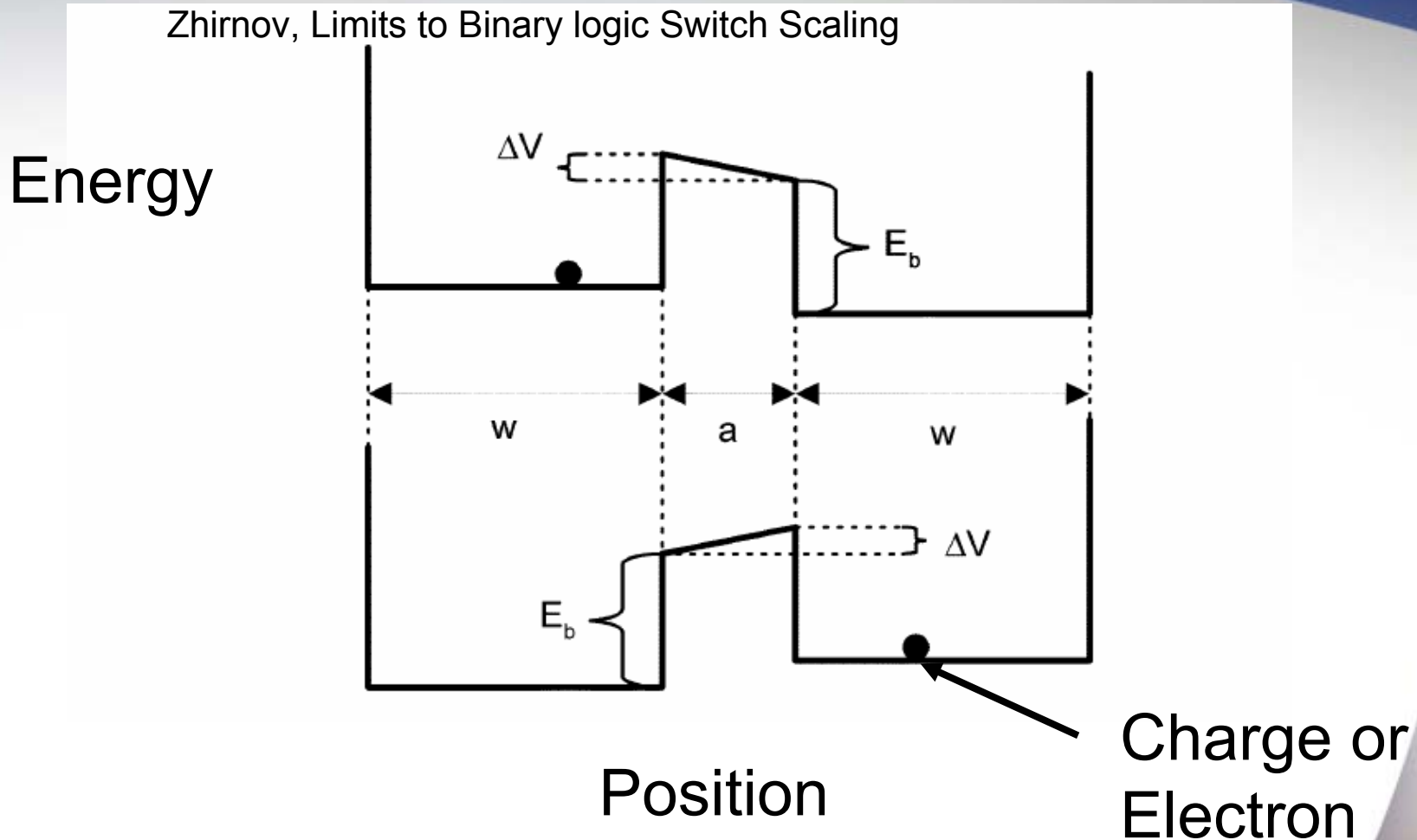

What are some requirements that information is not lost?

# Quantum Limit

Zhirnov, Limits to Binary logic Switch Scaling

$$\Delta x \Delta p \geq \hbar$$

$$\Delta E \Delta t \geq \hbar.$$

$$\begin{aligned} x_{\min} &= \frac{\hbar}{\Delta p} \\ &= \frac{\hbar}{\sqrt{2m_e E_{\text{bit}}}} \\ &= \frac{\hbar}{\sqrt{2m_e k_B T \ln 2}} \\ &= 1.5 \text{ nm} \quad (T = 300 \text{ K}). \end{aligned}$$

Quantum mechanic allows for a very small switch. Other factors materials limits / transistors electro-statics WILL limit before this.

# What does this mean

- Charge controlled switches as small as 1.5nm are possible.
- 23X smaller than state of the art MOSFET (35nm)
- Interpretation
  - Much smaller size electronics possible
  - Best case 18 years left for MOSFET scaling
  - But material limits (Si) and device structure limits will occur first.